

Series F61 Liquid Flow Switches

Introduction

The F61 liquid flow switches can be used in liquid lines carrying water, sea water, swimming pool water, ethylene glycol or other liquids not harmful to the specified materials. The switches have SPDT contacts and can be wired to energise one device and de-energise another device powered from the same source when liquid flow either exceeds or drops below the set flow rate. There are two different models available. The pipe insert models and the T-body types for low-flow applications. All materials in contact with the liquid are specified in the part "specifications". At doubt about the liquid used with regards to these materials it is advised to contact the liquid supplier. The IP43 versions can be used for liquid temperatures above dewpoint while the vapour proof IP67 versions can be used for liquid temperatures of minus 30°C and up or in high moisture environments. Typical applications are to shut down the compressor on liquid chiller systems, to prove flow on electric immersion heaters and to give a signal or alarm when the pump on condenser cooling system shuts down.



F61 Liquid Flow Switches

Feature and Benefits

<input type="checkbox"/> T-body and Pipe-insert types available	For low flow applications (0.04 dm ³ /s) up to flows of 48 dm ³ /s
<input type="checkbox"/> Polycarbonate IP43 enclosure	For indoor and outdoor applications.
<input type="checkbox"/> Vapour tight IP 67 enclosure	For low temperature applications.
<input type="checkbox"/> Stainless steel Pipe-insert type	Used for liquids like swimming pool water
<input type="checkbox"/> Large wiring space	Makes wiring convenient and easily accessible
<input type="checkbox"/> Range screw easy accessible	Easy to adjust in the field

Note

These controls are designed for use only as operating controls. Where an operating control failure would result in personal injury or loss of property, it is the responsibility of the installer to add devices or systems that protect against, or warn of, control failure.

Caution

Do not use with hazardous fluids or in hazardous atmosphere

Installation

Pipe-insert types

To allow the switch to detect changes in the liquid flow, the paddle must not touch the pipe or any other obstacle in the pipe. The Pipe-insert types are mounted on top of the liquid line. An angle of 120° is allowed as indicated in Fig. 1. To keep the flow switch close to the pipe and to provide an adequate paddle length in the flow stream the use of a reducing tee for larger pipe sizes is advised. The arrow on the cover must point in the flow direction. To avoid turbulence it is advised to mount the controller at a distance of minimal 10xD (on each side) away from elbows, valves and other appendages. The Pipe-insert types can be mounted in a vertical pipe as long as the flow is up-stream. This mounting position affects the adjustment of the controller.

The 6" paddle can be trimmed as indicated on page 6. For added stiffness it is advised to mount the smaller paddles behind the largest one.

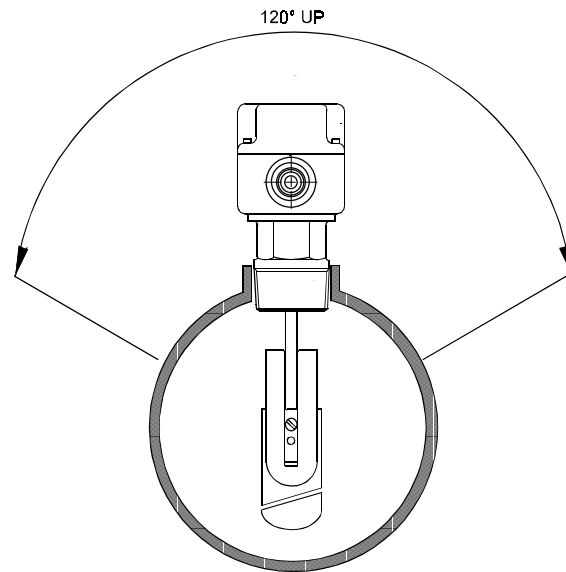

Fig1

T-body types

These types are mounted in the liquid line with the housing at the top. An angle of 120° is allowed as indicated in Fig. 1. The arrow on the body and cover must point in the flow direction. To avoid turbulences it is advised to mount the controller at a distance of minimal 10xD (on each side) away from elbows, valves and other appendages. The T-body types cannot be mounted in a vertical pipe.

Wiring

A special vapour proof PG-16 nipple for cable inlet is delivered by the IP67 type controls. This nipple has to be used to keep the control vapour tight.

Contact function

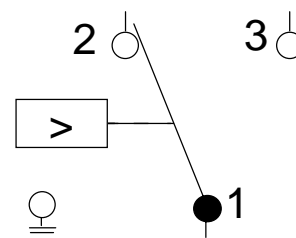

Fig. 2

1-3 closes on flow increase.

Adjustment

The switches are factory set at minimal flow setting. On the application the setting can be adjusted by the range screw under the cover as indicated in fig. 3. For higher flow rates turn the adjusting screw clockwise.

Note

Prevent to adjust the setting below factory setting as this may result in the switch failing to return to "no flow" position.

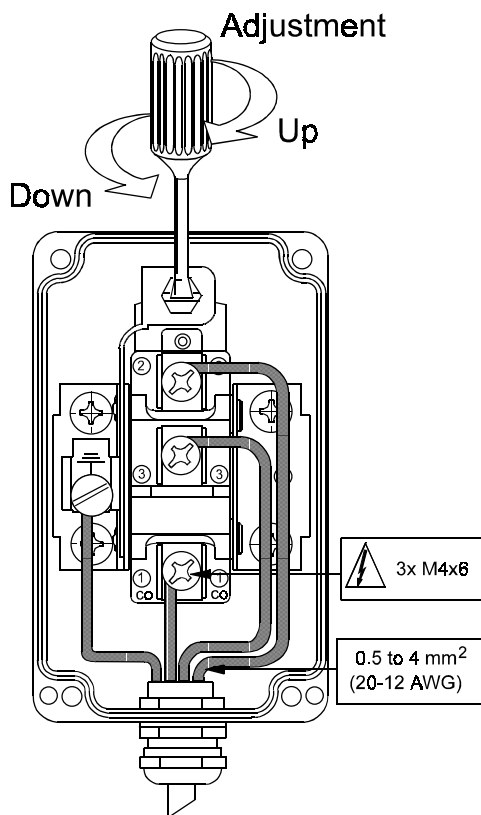

Fig. 3

Flow rates

Note : Please note that these curves are approximate data obtained in a laboratory test by use of water and are not necessarily representative or accurate when compared with various field applications. Values are affected by the liquid used and the mounting position of the controller. Flow rates for pipe sizes 3" and up are calculated values.

Flow rates T-body Types

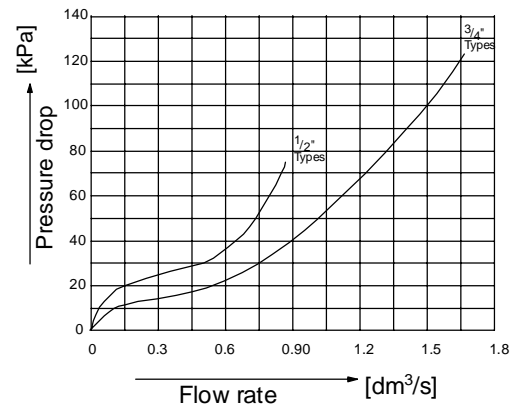

Fig. 4

Pressure drop Pipe Insert Types

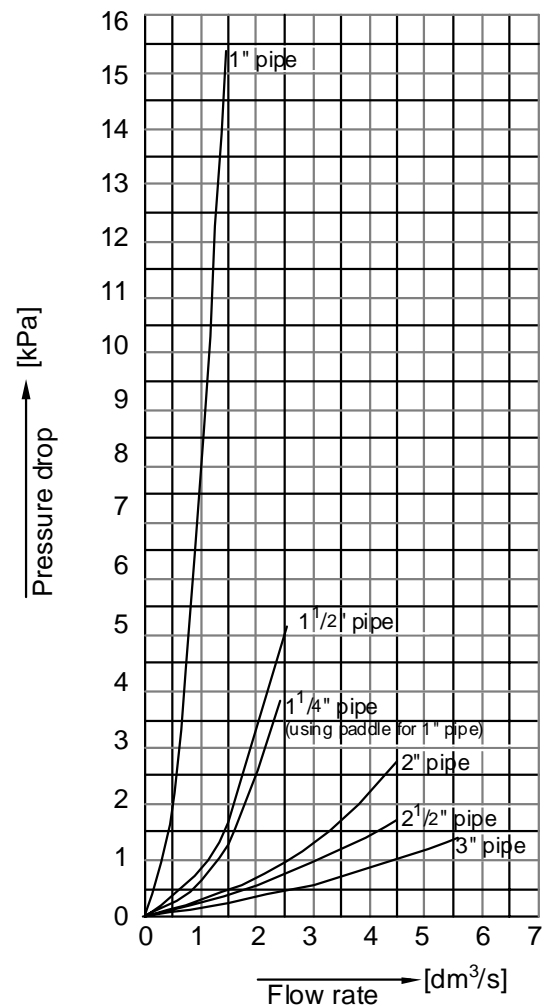

Fig. 5

Flow rate table Pipe Insert Types

		Paddle size		Line pipe size									
				1"	1 1/4"	1 1/2"	2"	2 1/2"	3" *	4" *	5" *	6" *	8" *
Minimum adjustment	Flow	1"-2"-3"	dm ³ /s	0.3	0.4	0.5	0.9	1.1	1.7	4.2	7.8	12	24
	increase		(m ³ /h)	(1.0)	(1.3)	(1.7)	(3.1)	(4.1)	(6.2)	(15)	(28)	(43)	(85)
	1-3 closes	6"	dm ³ /s	-	-	-	-	-	-	2.4 #	3.6 #	4.8	13
			(m ³ /h)	-	-	-	-	-	-	(8.5) #	(13) #	(17)	(47)
	Flow	1"-2"-3"	dm ³ /s	0.15	0.2	0.3	0.6	0.8	1.2	3	6.4	10	20
	decrease		(m ³ /h)	(0.6)	(0.8)	(1.1)	(2.2)	(2.8)	(4.3)	(11)	(23)	(36)	(73)
	1-2 closes	6"	dm ³ /s	-	-	-	-	-	-	1.7 #	2.5 #	3.4	11
			(m ³ /h)	-	-	-	-	-	-	(6) #	(9) #	(12)	(39)
Maximum adjustment	Flow	1"-2"-3"	dm ³ /s	0.6	0.9	1.2	1.8	2.2	3.4	8.1	16	24	48
	increase		(m ³ /h)	(2.0)	(3.0)	(4.4)	(6.6)	(7.8)	(12)	(29)	(56)	(85)	(173)
	1-3 closes	6"	dm ³ /s	-	-	-	-	-	-	5.0 #	7.6 #	9.2	26
			(m ³ /h)	-	-	-	-	-	-	(18) #	(27) #	(33)	(94)
	Flow	1"-2"-3"	dm ³ /s	0.5	0.8	1.1	1.7	2.0	3.2	7.8	1"5	23	43
	decrease		(m ³ /h)	(1.9)	(2.8)	(4.1)	(6.1)	(7.3)	(11.4)	(28)	(53)	(82)	(116)
	1-2 closes	6"	dm ³ /s	-	-	-	-	-	-	4.8 #	7 #	8.7	25
			(m ³ /h)	-	-	-	-	-	-	(17) #	(25) #	(31)	(91)

1 dm³/s = 3.6 m³/h = 15.6 U.S. gal./min. = 13 U.K. gal./min.

* Flow rates for these sizes are calculated.

For 4" and 5" line pipe the 6" paddle is trimmed

Accessories for Pipe-insert types

KIT21A600 : 1", 2", 3" paddle, phosphor bronze

KIT21A601 : 6" paddle, phosphor bronze

KIT21A602 : 1", 2", 3" and 6" paddles stainless steel AISI 301

Repair and replacement

Repair is not possible. In case of an improperly functioning control, please check with your nearest supplier. When contacting the supplier for a replacement you should state the type/model number of the control. This number can be found on the data plate or cover label.

Type number selection table

Pipe-insert	Range dm ³ /sec.	Connection	IP class	Paddles phosphor br. ASTM B103	Paddles st. st AISI 301	Paddles st. st AISI 304	Application
F61SB-9100	0.15/46	R1"DIN2999(ISO R7)	IP43	1", 2", 3"	–	–	Water/Ethylene glycol
F61SB-9103	0.15/46	R1"DIN2999(ISO R7)	IP43	1", 2", 3"	6"	–	Water/Ethylene glycol
F61TB-9100	0.15/46	1-11/2 NPT	IP67	1", 2", 3"	6"	–	Brine, sea water
F61TB-9102	0.15/46	1-11/2 NPT	IP67		1", 2", 3", 6"	–	Brine, sea water
F61TB-9103	0.15/46	R1"DIN2999(ISO R7)	IP67	1", 2", 3"	6"	–	Water/Ethylene glycol
F61TB-9200	0.15/46	R1"DIN2999(ISO R7)	IP67	–	–	1", 2", 3"	Sea water, swimming pool water

T-Body	Range dm ³ /sec.	Connection	IP class	Application
F61SD-9150	0.04/0.07	1/2-14 NPTF	IP43	Water/Ethylene glycol
F61SD-9151	0.08/0.11	1/2-14 NPTF	IP43	Water/Ethylene glycol
F61SD-9175	0.04/0.07	3/4-14 NPTF	IP43	Water/Ethylene glycol
F61TD-9150	0.04/0.07	1/2-14 NPTF	IP67	Water/Ethylene glycol

Note : Paddles not mounted, packed with the control.

Dimensions

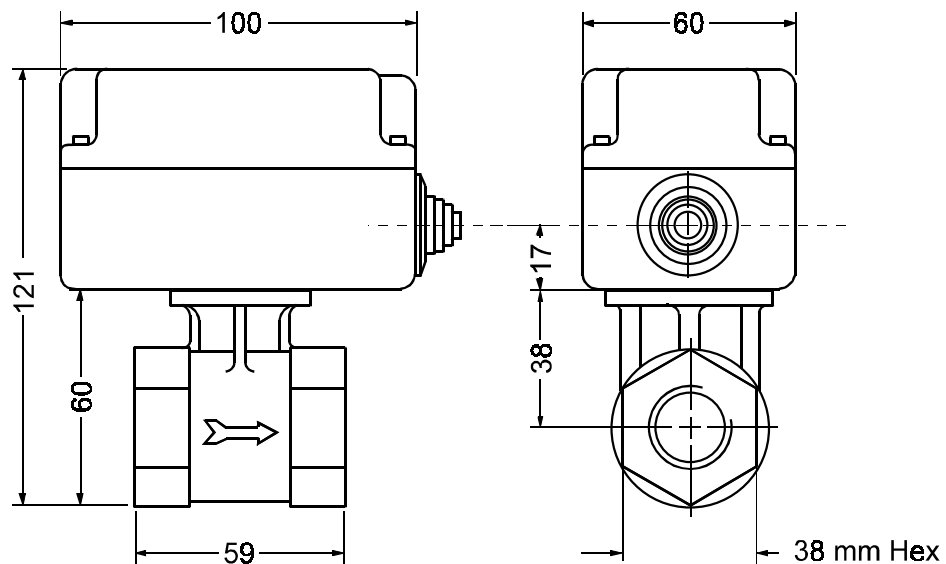

Fig. 6
F61SD/TD

- A . Cable inlet hole \varnothing 22.3 mm; Grommet installed on IP43 types.
- B . Vapour proof PG-16 nipple delivered with IP67 types

Dimensions

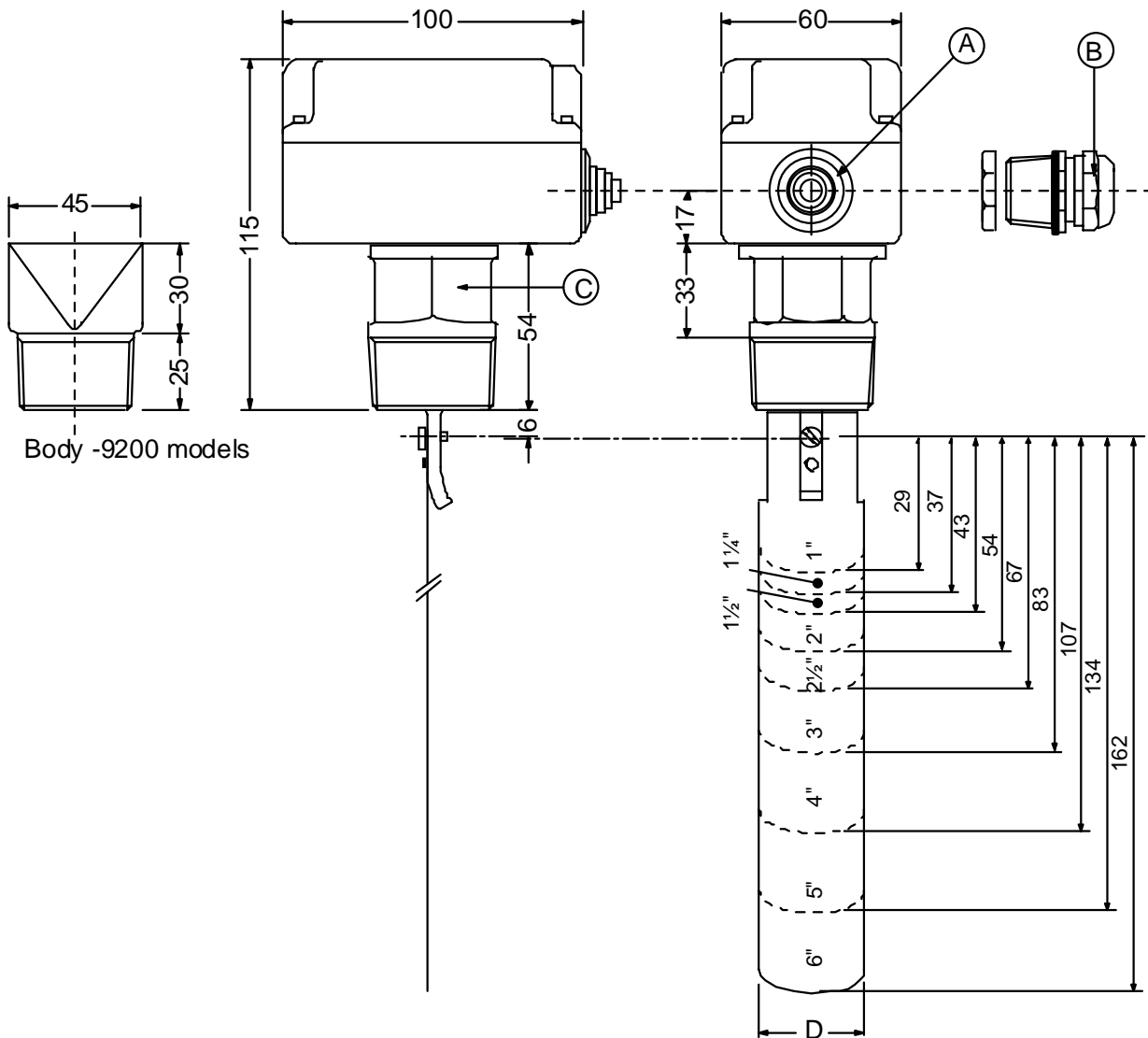

Fig. 7
F61SB/TB

- A. Cable inlet hole \varnothing 22.3 mm; grommet is installed on IP43 types.
- B. Vapour proof PG-nipple delivered with IP67 types.
- C. 30 mm Hex. F61SB/TB
45 mm F61TB-9200
- D. 1" paddel D = 25mm
2", 3", 6" paddel D = 29 mm

Note

Specifications

Pipe Insert Types					T-body Types	
Type number	F61SB-9100 F61SB-9103	F61TB-9100 F61TB-9102	F61TB-9103	F61TB-9200	F61SD-91xx	F61TD-9150
Flow Rates	see selection table					
Pipe connection	see selection table					
Max liquid pressure	10 bar	10 bar	10 bar	10 bar	10 bar	10 bar
Max. liquid temp.*	100°C	100°C	100°C	100°C	100°C	100°C
Min. liquid temp.**	0°C	-30°C	-30°C	-30°C	0°C	-30°C
Max. ambient temp.*	+55°C	+55°C	+55°C	+55°C	+55°C	+55°C
Min. ambient temp.**	-40°C	-40°C	-40°C	-40°C	-40°C	-40°C
Ambient humidity	10-95%	10-95%	10-95%	10-95%	10-95%	10-95%
Contact type	SPDT snap-acting switch					
Electrical rating	15(8) A 230Vac					
Wiring connections	screw terminals 1 up to 2.5mm ²					
Enclosure	IP43	IP67 Vapour proof	IP67 Vapour proof	IP67 Vapour proof	IP43	IP67 Vapour proof
Materials cover / case	Polycarbonate					
Materials in contact with liquid	see selection table					
Paddles	see selection table					
Bellows	phosphor bronze CuSn 6	phosphor bronze CuSn 6	phosphor bronze CuSn 6	stainless steel AISI 316L DIN1.4404	phosphor bronze	phosphor bronze
Rod	brass CuZn36Pb1.5	brass CuZn36Pb1.5 nickel plated	brass CuZn36Pb1.5	stainless steel AISI 316L DIN1.4401	bronze ASTM B140 alloy 316	bronze ASTM B140 alloy 316
Body	brass CuZn40Pb2	brass ASTM B584 alloy C84400	brass CuZn40Pb2	stainless steel AISI 316 DIN1.4401	brass ASTM B584 alloy C84400	brass ASTM B584 alloy C84400
Bellows washer	brass CuZn37F38	brass CuZn37F38 nickel plated	brass CuZn37F38	–	red brass	ASTM B36 alloy 3
Body washer	brass CuZn37F38	–	brass CuZn37F38	–	phosphor bronze ASTM B103 alloy Al	phosphor bronze ASTM B103 alloy Al
Screw paddle conn.	¼ hard brass	silicon bronze	¼ hard brass	stainless steel AISI 316 DIN1.4401	¼ hard brass	¼ hard brass
Washer paddle conn.	phosphor bronze	phosphor bronze	phosphor bronze	stainless steel AISI 316 DIN1.4401	–	–
Seat	–	–	–	–	red brass ½ hard	red brass ½ hard
Silver solder	L-Ag45	–	L-Ag45	–	SN50Pb	SN50Pb
Softsolder	L-SnAg5	L-SnAg5	L-SnAg5	–	Ag 15 P	Ag 15 P
Shipping weight individual pack	0.7 kg	0.7 kg	0.7 kg	1.0 kg	1.0 kg	1.0 kg
overbox	15 kg (24 pcs)	15 kg (24 pcs)	15 kg (24 pcs)	22 kg (24 pcs)	22 kg (24 pcs)	22 kg (24 pcs)
Vibration	acc.to DIN 89011 Kennlinie I					

* The max. liquid temperature of 100°C is at 20°C ambient. At higher ambient temperatures the max. allowed liquid temp. becomes lower. The temperature of the electrical switch inside should not exceed 70°C.

** The low liquid temperature combined with a low ambient temp. should not lead to freezing of the liquid inside the body / bellows. Please observe the liquid freezing point.

The performance specifications are nominal and conform to acceptable industry standards. For applications at conditions beyond these specifications, consult the local Johnson Controls office or representative. Johnson Controls shall not be liable for damages resulting from misapplication or misuse of its products.

**JOHNSON
CONTROLS**

Johnson Controls International, Inc.

Headquarters: Milwaukee, WI, USA
 European Headquarters: Westendhof 8, 45143 Essen, Germany
 European Factories: Lomagna (Italy), Leeuwarden (The Netherlands) and Essen (Germany)
 Branch Offices: Principal European Cities.

This document is subject to change

Printed in Europ